



Simply perfect.



The Vario programme Yale *lift 360*

Always different. Always with Yale *lift 360*.

new!



Vario programme

Yalelift 360

Yalelift 360



Chain guide



The patented Yale brake system

low noise and reduced wear.



High quality encapsulated ball bearings and sliding bushes

for smooth and effortless operation.

Hand chain hoist

Yalelift 360

Capacities 500 - 20.000 kg

The basis

Areas of operation as well as operator conditions have been improved in trail-blazing fashion, which goes far beyond the classical hand chain hoist.

- The revolutionary 360° rotating hand chain guide allows the operator to work from virtually any position, in confined spaces or above the load. The Yalelift can even be operated from the side of the load which also makes it possible to use the hoist for horizontal pulling or tensioning. Due to the additional flexibility, the operator is no longer forced to work in the danger zone near the load.

- The new patented brake system is extremely quiet and guarantees operational safety and improved serviceability due to omission of the vulnerable ratchet pawls.

All parts are made of high quality materials, additionally galvanised or yellow-chromated to increase corrosion prevention.

- The enclosed robust stamped steel housing protects all internal components even in the toughest conditions.
- The hardened load sheave with four precision machined pockets ensures accurate movement of the load chain.
- The extremely low headroom allows maximum use of the lifting height.
- The surface protected zinc-plated alloy steel load chains fulfil all requirements of current national and international standards and regulations.
- Drop forged load and suspension hooks that yield under overload instead of breaking, are made of high tensile steel and are standard for all Yale hoists. The hooks are fitted with robust safety latches and rotate 360°.

Optionally available with corrosion resp. spark resistant features.

Towerlift
Towerlift ES

Hand chain hoist

Towerlift

Capacities 1.000 - 2.000 kg

More flexibility

The *Towerlift* is the inverted version of the *Yalelift 360* and specifically designed for operation on traversing tower systems.

- The unit is provided with a special chain guide and a totally enclosed housing.
- The basic version of the *Towerlift* offers capacities of 1.000 kg and 2.000 kg.
- Black powder coat finish as standard.

Other colours, capacities and lifting heights available on request.



The robust stamped steel housing

with four stay bolts is resistant to the toughest working conditions.



The precisely machined load sheave

ensures accurate movement of the load chain.

Hand chain hoist

Towerlift ES

Capacity 1.000 kg

Additional application possibilities

The *Towerlift ES* is a further development of the *Towerlift*. Like the *Towerlift* the model *ES* is provided with a chain reeving system specifically designed for the stage /entertainment industry. This allows operation in standard hoist configuration as well as in inverted mode.

- The hoist comes with revolving chain container which can be fully used in standard hoist configuration as well as in inverted mode.
- Black powder coat finish.



Vario programme

Yalelift 360

Yalelift IT



Illustrated rubber buffers
optionally available!

Hand chain hoist
with integrated push type trolley

Yalelift ITP

Capacities 500 - 5.000 kg

Hand chain hoist
with integrated geared type trolley

Yalelift ITG

Capacities 500 - 5.000 kg

The combination of the Yalelift 360 with a low headroom manual trolley provides even more flexibility in the application of the Yalelift 360.

- All units of this series up to a capacity of 3.000 kg are provided with single chain fall and the min. headroom (Dim. A) has been further reduced. Ideal for applications with low ceilings and limited headroom.
- The manual trolleys are adjustable to fit a wide range of beam profiles (e.g. INP, IPE, IPB). Depending on the beam flange width an adjustment up to 300 mm can be made easily.
- The trolley wheels are designed for a max. beam profile incline of 14 % (DIN 1025 - part 1), excellent rolling features are guaranteed by pre-lubricated, encapsulated ball bearings.
- Anti-tilt and anti-drop devices are standard.
- A subsequent conversion of a Yalelift 360 into a Yalelift IT with integrated trolley is easily possible at any time.

Optional equipment and accessories
are given on pages 6 and 7!

Hand chain hoist
with integrated push type trolley
(Low headroom)

Yalelift LHP

Capacities 500 - 10.000 kg

Hand chain hoist
with integrated geared type trolley
(Low headroom)

Yalelift LHG

Capacities 500 - 10.000 kg

The hand chain hoist Model Yalelift LH with integrated low headroom manual trolley is the consequent further development of the Yalelift IT. Wherever an even smaller headroom is essential, the Yalelift LH is the ideal choice.

- The specially developed chain reeving system and chain guide allow the bottom block to be pulled laterally to the hoist even further up and almost against the beam flange.
- The integrated design of the innovative Yalelift LH uses the same manual trolleys as incorporated in the Yalelift IT series.
- All models of the LH series up to 3.000 kg capacity are provided with single chain fall.
- The proven and almost stepless adjustment system allows quick and easy assembly of the trolley.
- The low headroom version of the Yalelift IT is adjustable to fit a wide range of beam profiles (e.g. INP, IPE, IPB).
- The trolley wheels are designed for a max. beam profile incline of 14 % (DIN 1025 - Part 1).
- Excellent rolling features due to machined steel wheels mounted on pre-lubricated, encapsulated ball bearings.
- Anti-tilt and anti-drop devices as standard.
- The trolleys are offered for two beam ranges. Range A for a flange width up to 180 mm is standard and covers approx. 80 % of all requirements. Conversion to range B for beam width up to 300 mm can be easily accomplished.
- A subsequent conversion of a Yalelift 360 into a Yalelift LH with integrated trolley is also easily possible.



Illustrated rubber buffers
and chain container
optionally available!

**Yale hoists and trolleys are not designed
for passenger elevation applications
and must not be used for this purpose!**

Vario programme

Yalelift 360

Corrosion resistance
CR

Accessories



Illustrated rubber buffers
optionally available!

Corrosion resistance **CR**

Added lifetime

All models of the Yalelift Vario programme can be supplied with corrosion resistant features which include zinc-plated load chains and stainless steel hand chain as standard.

Corrosion protection

Corrosion starts on the surface of components due to reaction of environmental influences. This affects the mechanical properties of the components, e.g. breaking strength and total ultimate elongation. Many components are supplied in black (unmachined), bright (machined) or painted condition. This offers certain protection but after only a short period of time corrosion can begin.

With the application of a protective coating, the development of corrosion can be reduced and delayed, thus extending the service life of the treated components.

Applications for corrosion resistant units and zinc-plated resp. stainless steel load chains

Completely corrosion resistant units with either zinc-plated or stainless steel load chains should be used in all conditions with increased requirements towards corrosion protection.

Typical applications are in food processing (e.g. dairy, abattoir, etc.), chemical industries (e.g. paper, dye industries), farming and sewage treatment.

*All units available
in corrosion resistant
version!*

Spark resistant features

Added safety

All models of the Yalelift Vario programme can be provided with the following optional features for additional protection against sparking:

- Load and hand chains from stainless steel
- Units completely corrosion resistant
- Bronze-plated suspension and load hooks
- Solid bronze trolley wheels
- Rubber buffers
- Chain containers



Solid bronze trolley wheels

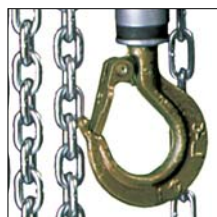

Bronze-plated suspension and load hooks

Spark resistance

In nearly all industrial areas, and not only in the chemical industry, plants are operated in explosion endangered environments. Because of the great damage an explosion could cause to people and material, stringent legal and technical requirements are imposed, particularly on electrical equipment used in explosion endangered environments.

Applications

Paint factories, paint shops, foundries, on-/offshore, refineries, oil depots, electro-plating, automobile factories, on ships and docks, printers, textile and paper factories, food industries, glass and ceramic industries, wood working industries and hardening shops, etc.

Overload protection

Added control

The overload protection device of the Yalelift Vario programme reliably prevents excessive load take-up of the hoist during operation. When reaching the pre-set overload value, the unit will jam and stop operation in the lifting direction. Lowering of the load is still possible at any time.

The overload protection device provides additional safety with regard to possible false estimation of the load weight and thus increases the lifetime of the hoist. The new design principle allows excellent adjustability and response.



Beam locking device

Added security

Yale trolleys can be optionally provided with beam locking device to secure the unloaded trolley in fixed position on the beam (park position e.g. on ships).

Chain container

Added comfort

The chain containers for the Yalelift Vario programme consist of a robust, powder-coated steel frame with a flexible chain bag made from high tensile Cordura textile fabric. Available in different sizes. Special sizes on request.



Vario programme

Yalelift 360

Tecnical data



Model	Capacity	Number of chain falls	Chain dimensions	Hand chain overhaul for 1 m lift	Pull on hand chain at WLL	Net weight at std. lift (3 m)
	kg		d x p in mm	m	daN	kg
Yalelift 360	500	1	5 x 15	30	21	9
	1000	1	6 x 18	49	30	13
	2000	1	8 x 24	71	32	20
	3000	1	10 x 30	87	38	29
	5000	2	10 x 30	174	34	38
	10000	3	10 x 30	261	44	71
	20000	6	10 x 30	522	2 x 44	196
Towerlift	1000	1	6 x 18	49	30	14
	2000	1	8 x 24	71	32	21
Towerlift ES	1000	1	6 x 18	49	30	15

Model	Capacity kg	Number of chain falls	Beam range	Beam flange width b mm	Beam flange thickness t max. mm	Min. radius curve m	Net weight in kg for 3 m lift			
							with locking device			
							-P	-G	-P	-G
Yalelift IT	500	1	A	50 - 180	19	0,90	20	24	26	31
	500	1	B	180 - 300	19	0,90	21	25	27	32
	1000	1	A	50 - 180	19	0,90	27	32	35	40
	1000	1	B	180 - 300	19	0,90	29	33	37	41
	2000	1	A	58 - 180	19	1,15	44	49	52	57
	2000	1	B	180 - 300	19	1,15	46	50	54	58
	3000	1	A	74 - 180	27	1,40	77	82	86	91
	3000	1	B	180 - 300	27	1,40	79	84	88	93
	5000	2	A	98 - 180	27	1,80	125	130	135	140
	5000	2	B	180 - 300	27	1,80	129	134	139	144
Yalelift LH	500	1	A	60 - 180	19	0,90	27	31	33	38
	500	1	B	180 - 300	19	0,90	27	32	34	38
	1000	1	A	70 - 180	19	0,90	35	40	43	48
	1000	1	B	180 - 300	19	0,90	36	41	44	49
	2000	1	A	82 - 180	19	1,15	61	65	69	73
	2000	1	B	180 - 300	19	1,15	62	67	70	75
	3000	1	A	100 - 180	19	1,40	107	112	116	121
	3000	1	B	180 - 300	19	1,40	109	114	118	123
	5000	2	A	110 - 180	27	1,80	152	157	162	167
	5000	2	B	180 - 300	27	1,80	156	161	166	171
10000	3	B	125 - 310	40	1,80					on request



The Vario programme Yalelift 360

Always different. Always with Yalelift 360.

Yalelift 360 for operation from all positions ✓

Towerlift for application on traversing tower systems ✓

Towerlift ES for operation in standard or inverted mode ✓

Yalelift IT with integrated manual trolley ✓

Yalelift LH to meet extremely low headroom requirements ✓

Optional:

CR corrosion resistant version of all models ✓

Accessories

- Spark resistant features ✓
- Overload protection ✓
- Beam locking device ✓
- Chain containers ✓



Dimensions

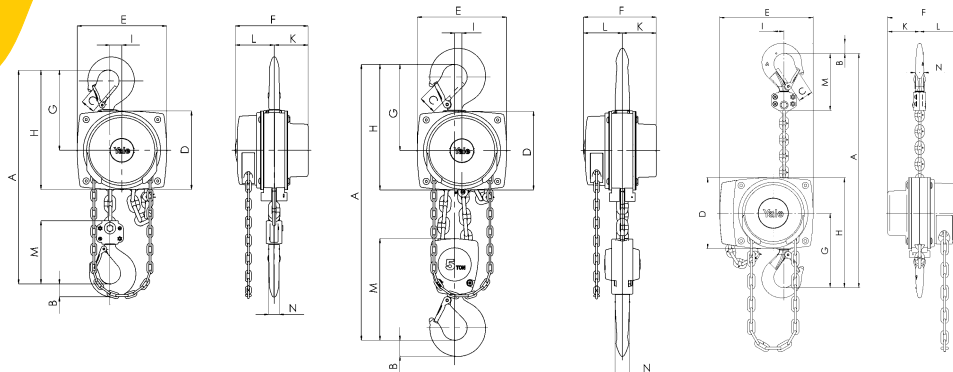

Yalelift 360 0,5t - 3,0t

Yalelift 360 5,0t

Towerlift

Dimensions in mm	Yalelift 360								Towerlift		Towerlift ES
	500	1000	2000	3000	5000	10000	20000	1000	2000	1000	
A _{min.}	300	335	395	520	654	825	980	335	395	335	
B	17	22	30	38	45	68	85	22	30	22	
C	24	29	35	40	47	68	74	29	35	29	
D	133	156	182	220	220	220	303	156	182	213	
E	148	175	203	250	250	383	555	205	243	232	
F	139	157	183	204	204	204	250	157	183	212	
G	139	164	192	225	242	326	391	164	192	164	
H	206	242	283	335	352	436	501	242	283	299	
I	24	24	31	34	21	136	-	24	31	24	
K	61	70	83	95	95	95	396	70	83	124	
L	79	87	100	109	109	109	125	87	100	88	
M	110	125	156	178	285	401	461	125	156	125	
N	14	19	22	30	37	50	56	19	22	19	
O	-	-	-	-	-	-	-	-	-	335	
P	-	-	-	-	-	-	-	-	-	593	
S	-	-	-	-	-	-	-	-	-	455	

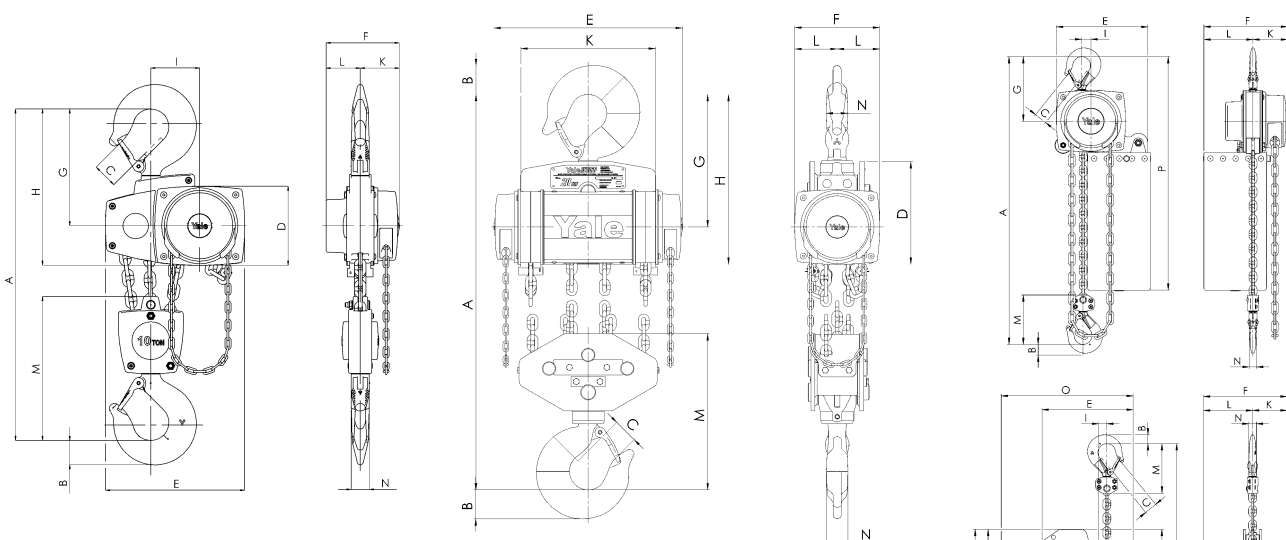

Yalelift 360 10,0t

Yalelift 360 20,0t

Towerlift ES

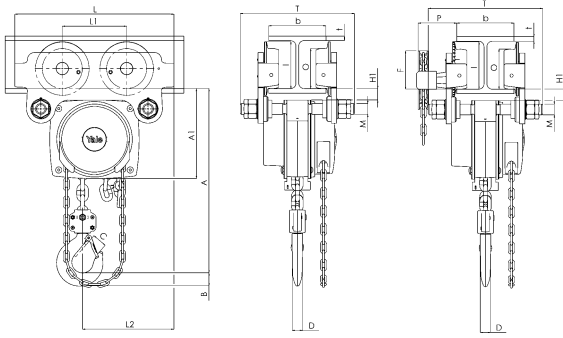

Yalelift ITP/G 0,5t - 3,0t

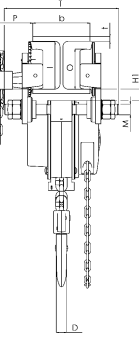

Yalelift ITG

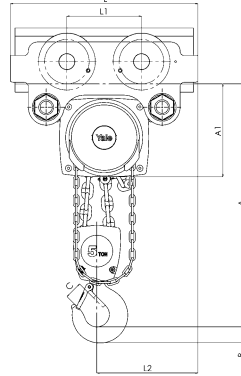

Yalelift ITP/G 5,0t

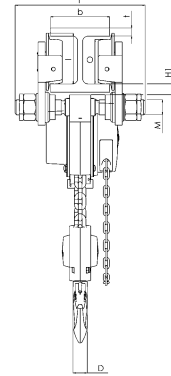

Yalelift ITG

Dimensions in mm	Yalelift IT					Yalelift LH				
	500	1000	2000	3000	5000	500	1000	2000	3000	5000
A _{min.}	245	272	323	382	550	188	211	264	316	425
A ₁	158	178	205,5	252	260,5	223	250	289	346	345
A ₂	-	-	-	-	-	381	427	511	614	612
B	17	22	30	38	45	17	22	30	38	45
C	24	29	35	40	47	24	29	35	40	47
D	14	19	22	30	37	14	19	22	30	37
F (geared)	92	92	91	107	149,5	92	92	91	107	150
H ₁	24,5	24	23,5	32	30,5	24	24	24	32	31
I (pushed)	71,5	71,5	95,5	131	142,5	72	72	96	131	143
I (geared)	76,5	76,5	98	132,5	148,5	77	77	98	133	149
L	270	310	360	445	525	270	310	360	445	525
L ₁	130	130	150	180	209	130	130	150	180	209
L ₂	159	175	207	256	283	444	488	582	690	720
L ₃	-	-	-	-	-	124	135	172	203	175
L ₄	-	-	-	-	-	184	201	230	265	283
M	M 18	M 22	M 27	M 30	M 42	M 18	M 22	M 27	M 30	M 42
O	60	60	80	112	125	60	60	80	112	125
P (geared)	108	110	112	112	117	108	110	112	112	117
T (Range A)	280	290	305	320	364	280	290	305	320	364
T (Range B)	400	410	425	440	484	400	410	425	440	484

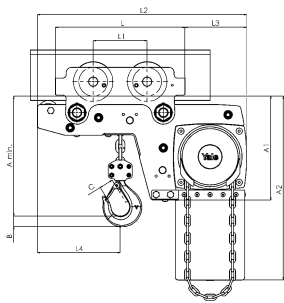

Yalelift LHP 0,5t - 3,0t

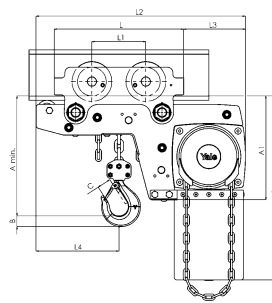
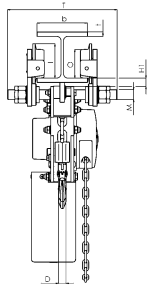

Yalelift LHG 0,5t - 3,0t

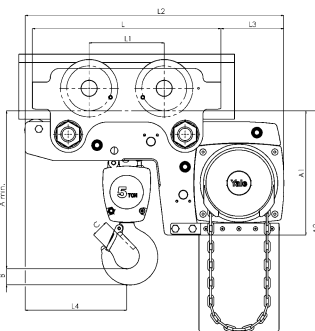
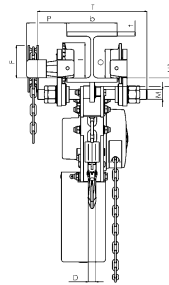

Yalelift LHP 5,0t

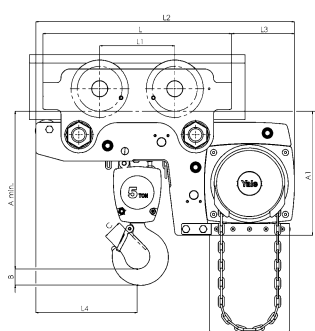
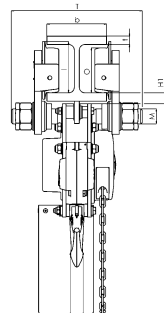

Yalelift LHG 5,0t

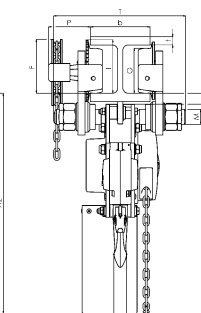



Certified since November 1991

Your local distributor: